

JUKI®

BE4504TOPJA

model **DLU-450-4**

高速一本針本縫上下送り自動糸切り装置付マシン
Single Needle Top and Bottom Feed Lockstitch Industrial Sewing Machine
Equipped with an Automatic Undertrimmer

model **DLD-432-4**

高速一本針本縫差動送り自動糸切り装置付マシン
Single Needle Differential Feed Lockstitch Industrial Sewing Machine
Equipped with an Automatic Undertrimmer

自動糸切り装置専用部品
Exclusive Parts for Automatic Undertrimmer

PARTS BOOK

TOKYO JUKI INDUSTRIAL CO., LTD.

HOW TO MAKE USE OF THIS PARTS BOOK

- As a basic principle, this parts book is divided into various sections according to the functions of respective parts.
- The part numbers of parts shown in the figure indicate the corresponding numbers(Ref.No.) shown by the index.
- Explanation of codes

- 1) ① mark means this part is changed from the previous parts book.
② 01..... refer to "Note" explanation at bottom of page.
- 2) Codes on the "E.C. (Engineering change)" column
 - A.10/74 Added from October, 1974
 - D.1/75..... Obsoleted from January, 1975
 - When D.(obsoleted) and A.(added) are indicated together
D.12/74)
A.12/74)
- ③ When previous parts (Obsoleted part) and new parts (Added parts) are not interchangeable with each other:
In this case, even obsoleted parts(D.) can be ordered with the obsoleted part number, so select the parts with changed dates and place your orders.

(Example)

Ref. No.	Note	Part No.	Description	E.C.	品名	Amt. Req.
	注記	品番		変更年月		数量
1		B1401-100-000	Needle bar	D.12/74	ハリボー	—
1-1		B1401-100-000-A	Needle bar	A.12/74	ハリボー	1

- ④ In case when previous parts and new part are interchangeable with each other:
In this case the new part number is replaced on the "品名(Japanese)" column of the previous parts, so please order by the new part number.

(Example)

Ref. No.	Note	Part No.	Description	E.C.	品名	Amt. Req.
	注記	品番		変更年月		数量
1		B1105-200-000	Frame cover	D.12/74	B1105-300-000	—
		B1105-300-000	Frame cover	A.12/74	フレームカバー	1

- C.3/75 This indicates error was discovered in March, 1975 and so it was corrected to a new part number.
Please note that in this case, the corrected part number is shown in the part number column and the wrong part number is shown in the "品名(Japanese)" column, so please order by the correct part number.

(Example)

Ref. No.	Note	Part No.	Description	E.C.	品名	Amt. Req.
	注記	品番		変更年月		数量
1		B1105-500-000	Frame cover	C.3/75	B1105-600-000	1
		↑ Correct No.			↑ Wrong No.	

- M.5/75..... The amount required is changed from March, 1975
The new amount required is shown in the "Amt. Req." column.

3) Codes on the "Amt. Req." column

- 2 Indicates amount required is 2.
- 2.0 Indicates length in meters. (unit is meter)
- Indicates parts obsoleted from the parts book.
- (1) Indicates sub parts which construct the assembly part.
Assembly part is shown as "asm." and クミ in Japanese, in the "Description" column.

(Example)

Ref. No.	Note	Part No.	Description	E.C.	品名	Amt. Req.
	注記	品番		変更年月		数量
10		B1105-900-0A0	Frame cover asm.		フレームカバー クミ	1
11		B1105-900-000	Frame cover		フレームカバー	(1)
12		SS-8110310-SP	Screw 11/64-40 L=2.8		トメネジ 11/64-40 L=2.8	(2)

When Ordering The Spare Parts:

In order to ensure that we deliver the correct parts to you, please clearly state when ordering the corresponding PART NUMBER (e.g. B1109-012-A00) and also the PARTS BOOK NUMBER (e.g. 0010-01, given at the top right of the cover) or the MACHINE SERIAL NUMBER, because there are some parts which have been changed.

CONTENTS
目次

1. THREAD TRIMMER COMPONENTS 糸切り装置関係	1
2. TENSION RELEASE COMPONENTS 糸ユルメ関係	3
3. MOTOR PULLEY & TRUNKING CORD COMPONENTS モータープーリー・中継コード関係	5
4. EXCLUSIVE PARTS FOR WIPER ワイパー関係	6
5. AUTOMATIC REVERSE FEED COMPONENTS 自動逆送り装置関係	7
6. PRESSER LIFTING SOLENOID (AK-2) COMPONENTS (SPECIAL ORDER) 押エ上げソレノイド (AK-2) 関係 (特別注文部品)	9
7. EXCLUSIVE PARTS FOR DLU-450-4 DLU-450-4 専用部品	11
8. EXCLUSIVE PARTS FOR DLD-432-4 DLD-432-4 専用部品	12

CSMP

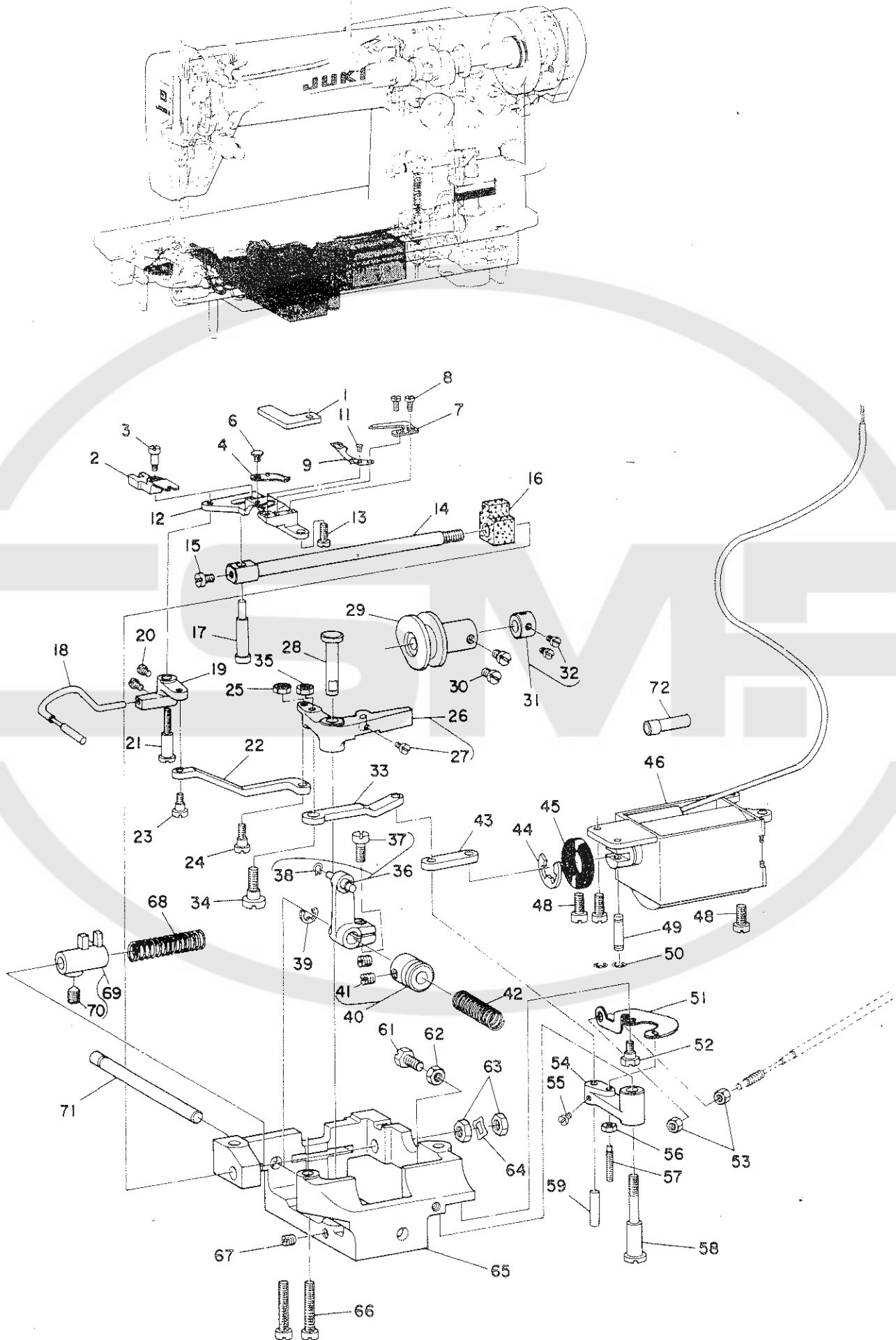

1. THREAD TRIMMER COMPONENTS

糸切り装置関係

Ref. No.	Note	Part No.	Description	E.C. 変更年月	品名	Amt. Req. 数量
1	003	D2422-555-B00	Groove cover		ベット溝フタ	1
2		D2411-555-B00	Knife driving fork		メスニ又	1
3		SD-0460702-SP	... Hinge screw D=4.60 H=7.0		メスニ又段ネジ	1
4		D2402-555-BA0	Moving knife asm.		動メス(組)	1
6		SD-0500095-TH	... Hinge screw D=5.00 H=0.85		動メス段ネジ	1
7		D2406-555-B00	Counter knife		固定メス	1
8		SS-4080620-TP	... Screw 1/8-44 L=6.4		固定メス止ネジ	2
9	003	D2405-555-B00-B	Thread guide		メス糸案内	1
11		SS-2060210-SP	Screw 3/32-56 L=2.3		メス糸案内止ネジ	1
12	003	D2401-555-BC0	Knife mounting base asm.		メス取付台(糸組)	1
13		SS-7111120-SP	... Screw 11/64-40 L=10.5		メス取付台止ネジ	1
14		D2424-555-B00-A	Knife driving shaft		メス作動軸	1
15		SS-7110740-TP	Screw 11/64-40 L=7.0		メスニ又ピン止ネジ	1
16	003	D2426-555-B00-A	Cushion		メス作動軸モルトブレーン	1
17		D2407-555-B00	Pin		メスニ又ピン	1
18	003	D2408-555-CA0	Needle thread picker asm.		釜糸押エ(組)	1
19	003	D2420-555-B00	Picker bracket		釜糸押エ腕	1
20		SS-6090510-SP	Screw 9/64-40 L=5.0		釜糸押エ止ネジ	2
21		SD-0641451-SP	Hinge screw D=6.35 H=14.5		釜糸押エ腕段ネジ	2
22		D2419-555-B00	Picker driving link		釜糸押エリンク	1
23		SD-0600401-TP	... Hinge screw D=6.00 H=4.0		釜糸押エリンク段ネジ	1
24		SD-0600402-TP	... Hinge screw D=6.00 H=4.0		釜糸押エリンク段ネジB	1
25		NS-6620310-SP	... Nut 3/16-32		釜糸押エリンク段ネジナット	1
26		D2416-555-BA0	Thread trimmer lever asm.		糸切り腕(組)	1
27		SS-7090910-SP	Screw 9/64-40 L=8.5		糸切り腕ピン止ネジ	(1)
28		D2431-555-B00	Thread trimmer shaft		糸切り腕軸	1
29		D2429-555-B00	Thread trimmer cam		糸切りカム	1
30		SS-6660710-TP	... Screw 1/4-40 L=7.0		糸切りカム止ネジ	2
31		CS-079101A-SH	Thrust collar asm.		糸切りカムスラスト受け(組)	1
32		SS-6110420-TP	... Screw 11/64-40 L=4.8		糸切りカムスラスト受け止ネジ	(2)
33		D2461-555-B00	Thread trimmer lever link		糸切り腕リンク	1
34		SD-0790432-SP	... Hinge screw D=7.94 L=4.3		糸切り腕リンク段ネジ	1
35		NS-6150310-SP	... Nut 15/64-28		糸切り腕リンク段ネジナット	1
36		D2415-555-BB0	Cam roller shaft bracket asm.		カムローラー軸腕(組)	1
37		SS-7151210-SP	... Screw 15/64-28 L=12.0		カムローラー軸腕締ネジ	(1)
38		D2430-555-B00	Stop ring		カムローラー軸Cリング	(1)
39		RE-0600000-K0	Snap ring		スライド軸止メ環	1
40		D2418-555-BA0	Thrust collar asm.		カムローラー軸スライド受け(組)	1
41		SS-8660810-TP	... Screw 1/4-40 L=8.0		カムローラー軸スライド受け止ネジ	(2)
42		D2423-555-B00	Pressing spring		スライド軸押シバネ	1
43		D2463-555-B00	Magnet connecting link		マグネットリンク	1
44		RE-1200000-K0	Snap ring		ブランジャー止メ環	1
45		D2468-555-B00	Rubber cushion		ブランジャーゴム	1
46		D2460-555-BA0	Solenoid asm.		ソレノイド(組)	1
48		SS-7151210-SP	Screw 15/64-28 L=12.0		ソレノイド止ネジ	3
49		D2464-555-B00	Pin		マグネットリンクピン	1
50		RE-0400000-K0	Snap ring		マグネットリンクピン止メ環	2
51		D3169-555-B00	Tension release wire driving lever		ワイヤー駆動レバー	1
52		SD-0630275-SP	... Hinge screw D=6.35 H=2.7		ワイヤー駆動レバー段ネジ	2
53		NS-6620310-SP	Nut 3/16-32		ワイヤーセットネジナット	1
54		D2465-555-B00-A	Lever driving arm		マグネット腕	1
55		SS-7110740-TP	... Screw 11/64-40 L=7.0		マグネット腕ピン止ネジ	1
56		NS-6110310-SP	Nut 11/64-40		ワイヤー駆動レバーピンナット	1
57		D3170-555-B00	Pin		ワイヤー駆動レバーピン	1
58		SD-0951905-SP	Hinge screw D=9.53 H=19.0		マグネット腕段ネジ	1
59		D2464-555-D00	Pin		マグネット腕ピン	1
61		SS-9151740-CP	Screw		糸切り腕ストッパー	1
62		NS-6150310-SP	Nut 15/64-28		糸切り腕ストッパーナット	1
63		NS-6680410-SP	Nut 9/32-28		メス作動軸ナット	2
64		WZ-0850302-K0	Waved washer		メス作動軸波座金	1
65	003	D2412-555-B00-A	Thread trimmer mounting base		糸切り取付台	1
66		SS-6153040-SP	... Screw 15/64-28 L=30.0		糸切り取付台止ネジ	2
67		SS-8660610-SP	Screw 1/4-40 L=6.0		糸切り腕軸止ネジ	1
68		D2423-555-B00	Spring		カムローラー軸ニ又押シバネ	1
69		D2414-555-BA0	Cam roller shaft forked bracket asm.		カムローラー軸ニ又(組)	1
70		SS-8660970-SP	... Screw 1/4-40 L=8.5		カムローラー軸ニ又止ネジ	(1)
71		D2425-555-B00	Slide shaft		スライド軸	1
72		D2469-555-B00	Tube, for magnet cord		マグコードパイプ	1

Note (注記) 03... For --DLU-450-4

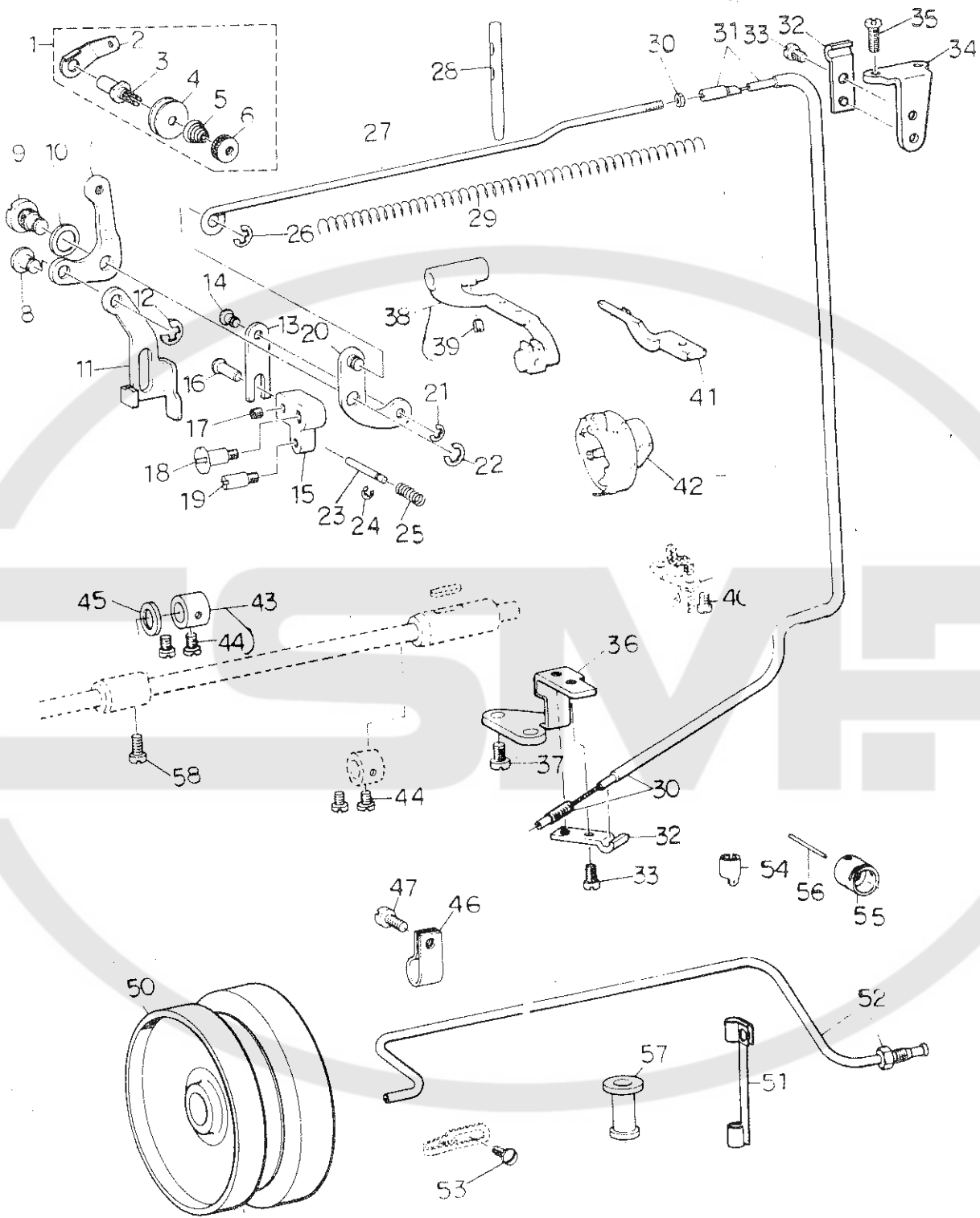

2. TENSION RELEASE COMPONENTS				糸コルメ関係		
Ref.No.	Note 注記	Part No. 品番	Description	E. C. 変更年月	品名	Amt. Req 個数
1		B3161555-B10	Thread tension NO.1 asm.		第一系調子棒(組)	1
2		D3162555-B00	Thread tension post thread guide		第一系調子棒案内	(1)
3		D3161555-B00	Thread tension post		第一系調子棒	(1)
4		B3214047-000	Thread tension disc		第一系調子皿	(1)
5		B3168555-B00	Thread tension spring		第一系調子バネ	(1)
6		B3216047-000	Thread tension nut		第一系調子ナット	(1)
7		D1516555-B00	Lifting lever link		引キ上げ板リンク	1
8		D1526555-B00	Pin		引キ上げ板連結ピン	1
9	002	D1517555-B00A	Shaft		引キ上げ板リンク軸	1
10		B3431581-000	Gasket		引キ上げ板リンク軸パッキン	1
11	002	D1515555-B00	Lifting lever		引キ上げ板	1
12		RE0500000-K0	Snap ring		引キ上げ板連結ピン止メ環	1
13	002	D3156555-B00	Tension release plate		糸コルメ板リンク	1
14		D3154555-B00	Stud		糸コルメ連結ピン	1
15		D3153555-B00	Tension release lever		糸コルメ腕	1
16		D3155555-B00	Pin		糸コルメ腕ピン	1
17		SS862061-0TP	Screw		糸コルメ腕ピン止ネジ	1
18		SD0641003-SP	Hinge screw		糸コルメ腕腕ネジ	1
19		D3157555-D00	Screw stud		引キ上げ板接触ピン	1
20	002	D3157555-BA0	Tension release link asm.		糸コルメリンク腕(組)	1
21		RE0300000-K0	Snap ring		糸コルメ連結ピン止メ環	1
22		RE0600000-K0	Snap ring		引キ上げ板リンク軸止メ環	1
23	002	D3127555-B00	Auxiliary pin		糸コルメ補助ピン	1
24	002	RE0250000-K0	Snap ring		糸コルメ補助ピン止メ環	1
25		D3133555-B00	Spring		糸コルメ補助ピン	1
26		RE0500000-K0	Snap ring		糸コルメ板リンクピン止メ環	1
27		D3165555-B00	Tension release rod		糸コルメロッド	1
28		B1114012-000	Needle thread guide pin		糸案内棒	1
29		B3404122-000	Spring		送りパイアバネ	1
30		NS606031-0SP	Nut		糸コルメロッドナット	1
31		D3150555-BA0	Tension release wire asm.		糸コルメワイヤー(組)	1
32		D3164555-B00	Outer presser plate		アウター押エ	2
33		SS7110740-TP	Screw		アウター押エ止ネジ	2
34		D3163555-B00A	Flexible tube support plate		フレキシブル取付台	1
35		SS7111120-SP	Screw		フレキシブル取付台止ネジ	2
36		D3167555-B00B	Tension release wire presser plate		ワイヤー押エ板	1
37		SS7110740-TP	Screw		ワイヤー押エ板止ネジ	2
38		D1602555-BC0	Feed bar asm.		送り台(組)	1
39		SS862061-0TP	Screw		送り台軸腕ネジ	(1)
40		SS7110710-SP	Screw		送り軸芯押エ止ネジB	1
41		D1835555-B00	Bobbin case holder positioning finger		中巻押エ	1
42		D1830555-BA0	Sewing hook asm.		送油釜(組)	1
43		CS079101ASH	Thrust collar asm.		下軸スラスト受ケ(B)(組)	1
44		SS6110420-SP	Screw		下軸スラスト受ケ(B)止ネジ	(4)
45		D1807555-B00	Stopper plate		下軸中×タルスラスト受板	1
46		D2112555-B00	Cord holder A		コード止×金具A	1
47		SS7150940-SP	Screw		コード止×金具A止ネジ	1
50		D1217555-C00	Hand wheel		ハズミ車	1
51		D3536555-B00	Oil tube holder		送油パイプ押エ	1
52		D3521555-BA0	Hook driving shaft oil pipe asm.		送油パイプ(組)	1
53		SS5090610-SP	Screw		アーム系案内(A)止ネジ	1
54		B1418552-A00	Needle thread guide		針棒糸掛ケ	1
55		B3111126-000	Thread tension post socket		糸調子棒台	1
56		B3118552-A00	Tension release pin		糸コルメピン	1
57	002	D2467555-B00	Rubber bushing		ゴムブッシュ	1
58		SS7150940-SP	Screw		下軸中×タル止ネジ	1
NOTE	002	Exchangeable parts when automatic reverse feed is used			自動送り装置使用の際、	60
	002	For DLD-432-4			交換される部品 DLD-432-4用	

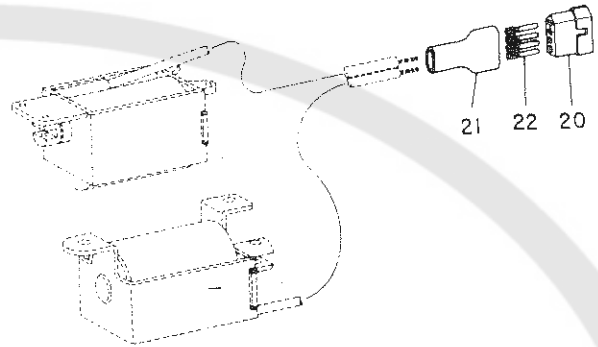
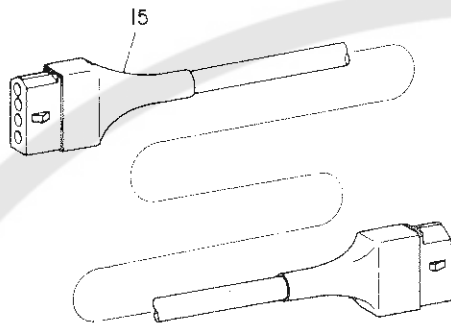
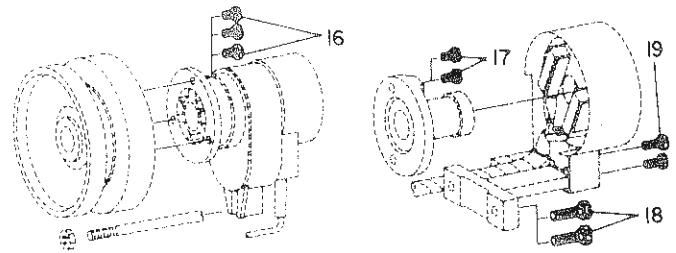
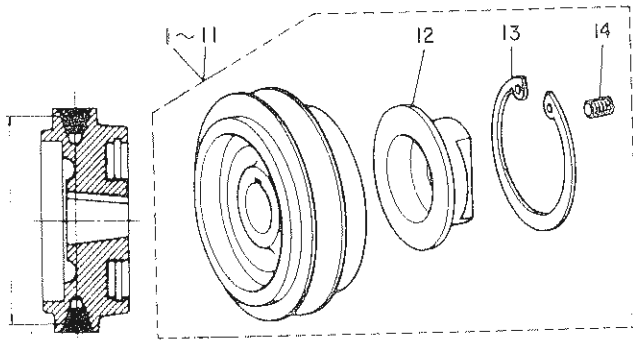

3. MOTOR PULLEY & TRUNKING CORD COMPONENTS

Ref. No.	Note	Part No.	Description
1		MTS-P00650A0	Motor pulley (P.C.D.65) asm.
2		MTS-P00700A0	Motor pulley (P.C.D.70) asm.
3		MTS-P00750A0	Motor pulley (P.C.D.75) asm.
4		MTS-P00800A0	Motor pulley (P.C.D.80) asm.
5		MTS-P00850A0	Motor pulley (P.C.D.85) asm.
6		MTS-P00900A0	Motor pulley (P.C.D.90) asm.
7		MTS-P00950A0	Motor pulley (P.C.D.95) asm.
8		MTS-P01000A0	Motor pulley (P.C.D.100) asm.
9		MTS-P01100A0	Motor pulley (P.C.D.110) asm.
10		MTS-P01150A0	Motor pulley (P.C.D.115) asm.
11		MTS-P01200A0	Motor pulley (P.C.D.120) asm.
12		MTS-P0001000	Motor pulley installing nut
13		RC-4800002-KP	C ring
14		SS-8150710-SP	Screw 15/64-28 L=7.0
15		D6001-555-DA0	Trunking cord asm.
16	04	SS-7110410-SP	Screw
17	03	SS-71111410-SP	Screw
18	03	SS-9151740-SP	Screw 15/64-28 L=17.0
19	03	SS-7110840-SP	Screw 11/64-40 L=8.0
20		MAI-15042000	Nylon plug 4P (WHITE)
21		D6008-555-D00	Plug cover 4P (WHITE)
22		D6043-555-B00	Pin-shape terminal, male

Note (注記) 03 For HITACHI motor
 04 For MATSUSHITA motor

モータープーリー・中継コード関係

E.C.	品名	Amt. Req.
変更年月		数量
	モータープーリー (P.C.D.-65)(組)	1
	モータープーリー (P.C.D.-70)(組)	1
	モータープーリー (P.C.D.-75)(組)	1
	モータープーリー (P.C.D.-80)(組)	1
	モータープーリー (P.C.D.-85)(組)	1
	モータープーリー (P.C.D.-90)(組)	1
	モータープーリー (P.C.D.-95)(組)	1
	モータープーリー (P.C.D.-100)(組)	1
	モータープーリー (P.C.D.-110)(組)	1
	モータープーリー (P.C.D.-115)(組)	1
	モータープーリー (P.C.D.-120)(組)	1
	モータープーリーナット	(1)
	モータープーリーナット止輪	(1)
	モータープーリーナット止ネジ	(1)
	中継コード (組)	1
	検出器取付ネジ	3
	検出器フランジ取付ネジ	2
	検出器ブラケット取付ネジ	2
	検出器カバー止メネジ	2
	4極ナイロンプラグ (白)	1
	4極フラクカバー (白)	1
	ピンターミナル (オス)	4
	日立モーター用	
	ナショナルモーター用	

4. EXCLUSIVE PARTS FOR WIPER

ワイパー関係

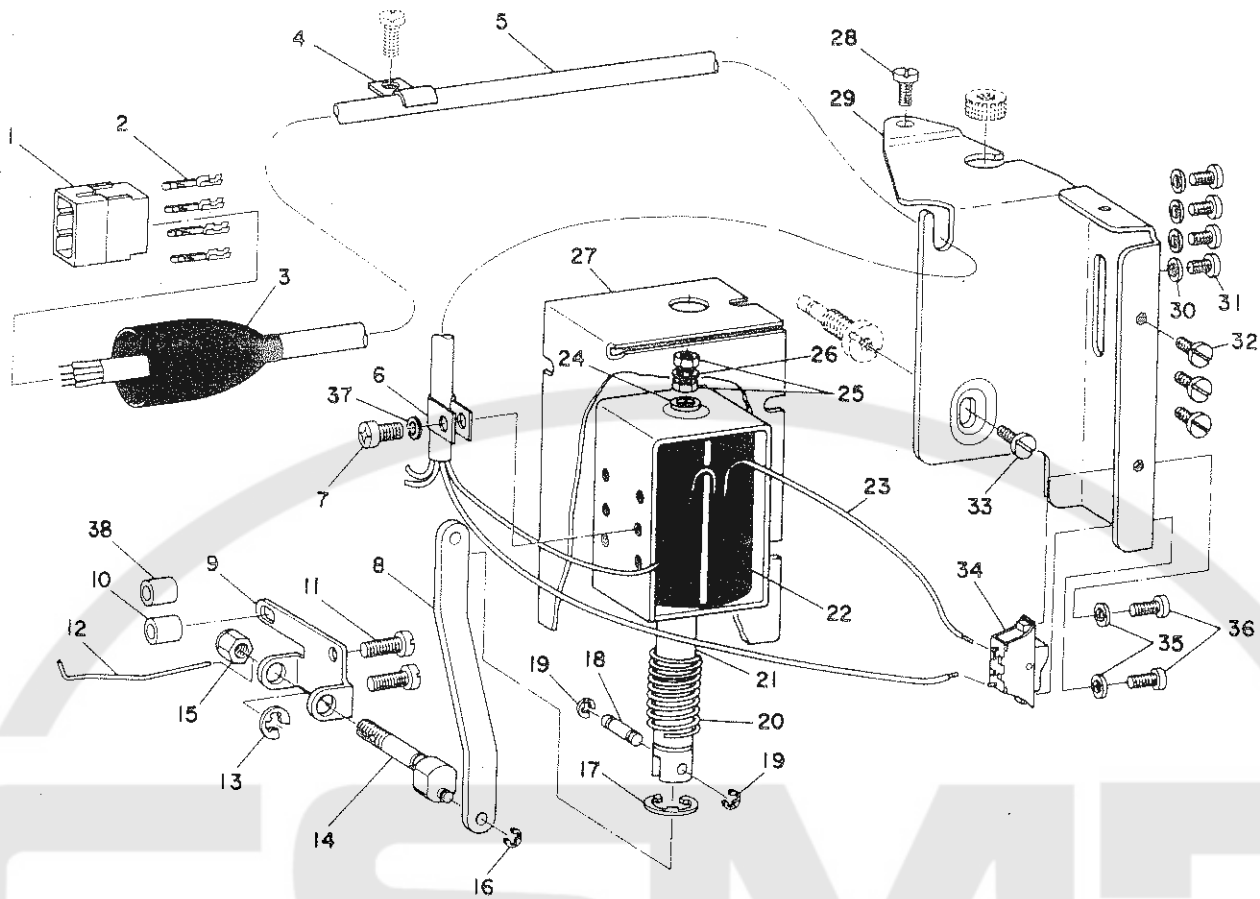

Ref. No.	Note	Part No.	Description	E.C.	品名	Amt. Req.
	注記	品番		変更年月		数量
1		D6029-555-B0A	6 pole plug (WHITE)		6p コンセント (白)	1
2		D6043-555-B00	Pin-shape terminal, male		ピンターミナル、オス	4
3		D6001-555-B00	Plug cover		プラグカバー A	1
4		D2611-555-B00-A	Cord holder		ケーブル止め金具	1
5		HW-6F18S12-48	4-core cabtyre cord		4心キャブタイヤコード	2.0
6		D2120-555-C00	Nylon cord holder		ナイロンクランプ	1
7		SM-4040801-SN	Screw M4 x 0.7 L=8.0		ナイロンクランプ止ネジ	1
8		D2102-555-B00	Wiper connecting link		ワイパー連結リンク	1
9		D2105-555-B00	Wiper driving shaft bracket		ワイパー作動軸ブラケット	1
10		D2114-555-B00	Collar		ブラケット取付カラー	1
11		SS-7112420-SP	Screw 11/64-40 L=24.0		ワイパー作動軸ブラケット止ネジ	2
12		D2104-555-C00	Wiper		ワイパー	1
13		RE-0500000-K0	Snap ring		ワイパー作動軸止め環	1
14		D2103-555-C00	Wiper driving shaft		ワイパー作動軸	1
15		B1415-352-000	Wiper set nut		ワイパー止ナット	1
16		RE-0250000-K0	Snap ring		ワイパー作動軸止め環	1
17		RE-0901110-K0	Snap ring		プランジャー止め環	1
18		D2107-555-B00	Wiper link connecting pin (A)		ワイパーリンク軸 A	1
19		RE-0250000-K0	Snap ring		ワイパーリンク軸止め環	2
20		MAT-80113T00	Spring		ワイパーマグバネ	1
21		D2118-555-B00-A	Plunger		プランジャー	1
22		D2117-555-B00-A	Wiper magnet		ワイパーマグネット	1
23		HW-2F18S12-19	Wiper magnet lead wire		ワイパーマグネットリード線	0.1
24		MAT-80115T00	Plunger stopper washer		プランジャーストッパー座	1
25		NM-6043212-SB	Nut M4 x 0.7		プランジャーストッパーナット	2
26		WS-0410002-KN	Washer		ストッパーナットワッシャー	1
27		D2111-555-B00-B	Magnet cover		マグネット取付台カバー	1
28		SS-7110840-SP	Screw 11/64-40 L=7.5		天秤カバー止ネジ	1
29		D2101-555-C00	Magnet installing base		マグネット取付台	1
30		WP-0480856-SD	Washer 4.8 x 8.4 x 0.8		ワイパーマグネット止ネジ座金	4
31		SM-4040601-SN	Screw M4 x 0.7 L=6.0		ワイパーマグネット止ネジ	4
32		SS-7110340-SP	Screw 11/64-40 L=3.2		マグネット取付台カバー止ネジ	3
33		SS-7110710-SP	Screw 11/64-40 L=7.0		マグネット取付台止ネジ	1
34		D2119-555-C00	Switch		ワイパーシーソーススイッチ	1
35		WP-0320500-MC	Washer M3		ワイパーシーソーススイッチ止ネジ座金	2
36		SM-4030601-SN	Screw M3 x 0.5 L=6.0		ワイパーシーソーススイッチ止ネジ	2
37		WP-0430800-SG	Washer M4		ナイロンクランプ止ネジ座金	1
38		D2121-555-D00	Collar B		ブラケット取付カラー B	1

5. AUTOMATIC REVERSE FEED COMPONENTS

自動進紙裝置關係

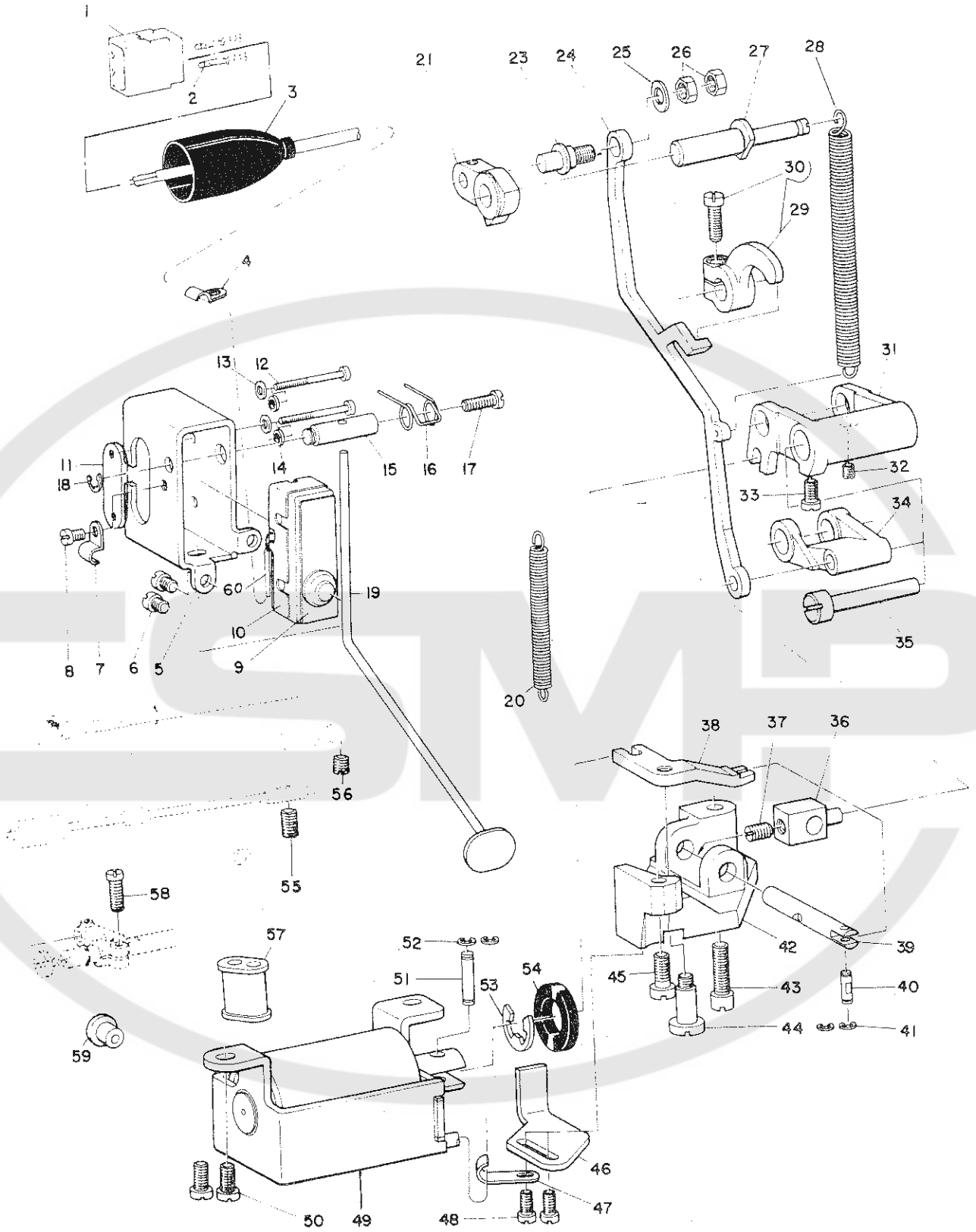

5. AUTOMATIC REVERSE FEED COMPONENTS

自動逆送り装置関係

Ref. No.	Note	Part No.	Description	E.C.	品名	Amt. Req.
	注記	品番		変更年月		数量
1	◆01	D6029-555-B0A	6 pole plug (WHITE)		6P コンセント (白)	1
2		D6043-555-B00	Pin-shape terminal, male		ピンターミナル、オス	2
3	◆01	D6001-555-B00	Plug cover (A)		プラグカバー A	1
4	◆01	B3538-112-000	Cord holder		コード止メ金具 C	1
5		D1627-555-B00-A	Reverse feed switch mounting base		逆送りスイッチ取付台	1
6		SS-7110740-TP	... Screw 11/64-40 L=7.0		逆送りスイッチ取付台止ネジ	2
7		B3538-112-000	Cord holder		逆送りコード押エ	1
8		SS-7110410-SP	... Screw 11/64-40 L=4.0		逆送りコード押エ止ネジ	1
9		D9204-555-C00	Microswitch		バック用マイクロスイッチ	1
10		D9205-555-B00	Microswitch cover		マイクロスイッチカバー	1
11		D9299-555-B00	Microswitch set plate		マイクロスイッチ止メ板	1
12		SM-4033001-SC	Screw M3 L=30.0		マイクロスイッチ止ネジ	2
13		WP-0320501-SC	Washer M3		マイクロスイッチ止ネジ座金	2
14		WS-0310002-KN	Spring washer		マイクロスイッチバネ座金	2
15		D1628-555-B00	Reverse feed switch lever shaft		逆送りスイッチレバー取付軸	1
16		D1635-555-B00	Spring		逆送りスイッチレバーバネ	1
17		SS-7111410-SP	Screw 11/64-40 L=14.0		逆送りスイッチレバー止ネジ	1
18		RE-0500000-K0	Snap ring		逆送りスイッチ取付軸止輪	1
19		D1625-450-DA0	Reverse feed switch lever asm.		逆送りスイッチレバー (組)	1
20		B2612-047-000	Tension spring		バックレバー引き上げバネ	1
21		D1618-555-B00	Feed regulator		送り調節台	1
23		D1633-555-B00-A	Rod pin		送り調節ロッドピン	1
24		D1619-555-B00-A	Connecting rod		送り調節ロッド	1
25		WP-0651056-SH	Washer 6.5x11.0x1.0		送り調節ロッドピン座金	1
26		NS-6660430-SP	Nut 1/4-40		送り調節ロッドピンナット	2
27		D1623-555-B00	Hinge pin		送り調節台止軸	1
28		D1624-450-B00	Tension spring		送り調節ロッドバネ	1
29		D1622-555-BA0	Reverse feed control lever crank asm.		送り腕 (組)	1
30		SS-7121410-SP	... Screw 3/16-28 L=14.0		送り腕止ネジ	1
31		D1616-555-B00	Feed driving rocker		送り調節リンク	1
32		SS-8110510-TP	Screw 11/64-40 L=5.0		送り調節リンク支エピン止ネジ	1
33		SS-7621040-SP	Screw 3/16-32 L=9.5		送り調節二又リンク支エピン止ネジ (B)	1
34		D1617-555-B00	Feed driving rocker arm		送り調節二又リンク	1
35		D1615-555-B00	Hinge pin		送り調節二又リンクピン	1
36		D1613-555-B00	Reverse feed connecting block		逆送り連結台	1
37		SS-8660970-TP	... Screw 1/4-40 L=8.5		逆送り連結台止ネジ	1
38		D1614-555-B00-A	Plunger connecting arm		逆送りプランジャー腕	1
39		D1612-555-B00	Reverse feed shaft		逆送り軸	1
40		D1620-555-B00	Connecting pin		逆送りプランジャー腕連結ピン A	1
41		RE-0300000-K0	Snap ring		連結ピン A 止メ輪	2
42		D1611-555-B00	Reverse feed base		逆送り台	1
43		SS-6152440-SP	... Screw 15/64-28 L=23.5		逆送り台止ネジ B	1
44		SD-0791331-SP	Hinge screw D=7.94 H=13.3		逆送りプランジャー腕段ネジ	1
45		SS-6151440-SP	Screw 15/64-28 L=14.0		逆送り台止ネジ A	1
46		D1632-555-B00	Reverse feed limited arm		バック量制限	1
47		D1630-555-B00	Cord holder		逆送りマグコード押エ	1
48		SS-6111110-SP	Screw 11/64-40 L=11.0		バック量制限腕ネジ	2
49		D6117-555-DAE-A	Reverse feed magnet asm.		逆送りマグネット (組)	1
50		SS-7150940-SP	... Screw 15/64-28 L=9.0		逆送りマグネット止ネジ	2
51		D1621-555-B00	Connecting pin		逆送りプランジャー腕連結ピン B	1
52		RE-0300000-K0	Snap ring		連結ピン B 止メ輪	2
53		RE-1200000-K0	Snap ring		プランジャー止メ環	1
54		D2468-555-B00	Rubber cushion		プランジャーゴム	1
55		SS-8150710-SP	Screw 15/64-28 L=7.0		下軸後メタル止ネジ	1
56		SS-8150410-SP	Screw 15/64-28 L=4.0		上下送り軸後メタル止ネジ	1
57		D1634-555-B00	Rubber bushing		ゴムブッシュ	1
58		SS-6121230-SP	Screw 3/16-28 L=12.0		引張バネ掛調節器腕締ネジ	1
59		B1117-552-000	Rubber plug		引張バネ掛軸ネジキャップ	1
60	◆01	HW-500070-00	2-core cable cord		2心キャブタイヤコード	1.9

Note (注記) ◆01 Exchangeable parts when wiper is used ワイパー使用の際、交換される部品

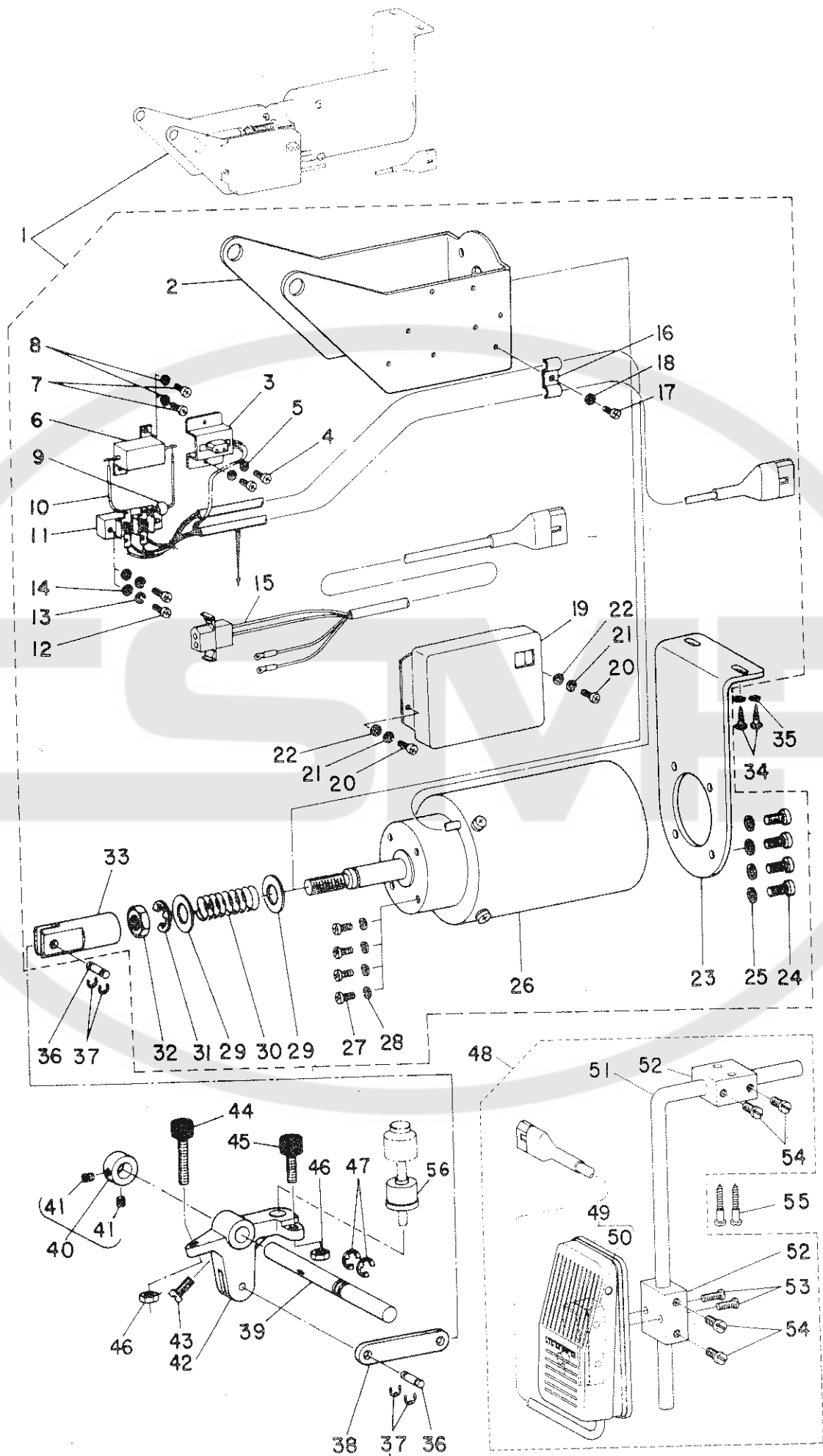

6. PRESSER LIFTING SOLENOID (AK-2) COMPONENTS (SPECIAL ORDER PARTS)

押エ上ゲソレノイド関係 (特別注文部品)

Ref. No.	Note	Part No.	Description	E.C.	Amt. Req.
	注記	品番		変更年月	数量
1		GAK-020050B0	Presser lifting solenoid asm.		1
2		GAK-01013000	Solenoid installing bracket B		(1)
3		GAK-01014000	2 pole receptacle installing base		(1)
4		SM-4030801-SB	Screw M3 x 0.5 L=8.0		(2)
5		WS-0310702-KS	Waved washer 3.1 x 5.3 x 0.7		(2)
6		HR-0036010-00	Metal clad wire wound resistor		(1)
7		SM-4030801-SB	Screw M3 x 0.5 L=8.0		(2)
8		WS-0310702-KS	Waved washer 3.1 x 5.3 x 0.7		(2)
9		HG-2674014-7P	Diode 1N5625		(1)
10		HW-2F18S12-12	Electric wire (RED)		(0.1)
11		GAK-01015000	2 pole terminal block		(1)
12		SM-4031401-SB	Screw M3 x 0.5 L=14.0		(2)
13		WS-0310702-KS	Waved washer 3.1 x 5.3 x 0.3		(2)
14		WP-0330501-SB	Washer M3		(2)
15		GAK-010210A0	Presser lifting cord asm.		(1)
16		GAK-01016000	Cord holder		(1)
17		SM-4030801-SB	Screw M3 x 0.5 L=8.0		(1)
18		WS-0310702-KS	Waved washer 3.1 x 5.3 x 0.3		(1)
19		GAK-01020000	Presser lifting cover		(1)
20		SM-4030801-SB	Screw M3 x 0.5 L=8.0		(2)
21		WS-0310702-KS	Waved washer 3.1 x 5.3 x 0.3		(2)
22		WP-0330500-MB	Washer M3		(2)
23		GAK-01012000	Solenoid installing bracket A		(1)
24		SM-4051001-SB	Screw M5 x 0.8 L=10.0		(4)
25		WS-0511302-KB	Waved washer		(4)
26		GAK-010050A0	Presser lifting solenoid		(1)
27		SM-4051001-SB	Screw M5 x 0.8 L=10.0		(4)
28		WS-0511302-KB	Waved washer		(4)
29		GAK-01018000	Thrust washer		(2)
30		GAK-01017000	Spring		(1)
31		RE-1200000-K0	Snap ring		(1)
32		NM-6100663-SE	Nut		(1)
33		GAK-01019000	Lifting lever shaft		(1)
34		SK-3514000-SD	Wood screw		2
35		WP-0520656-SA	Washer		2
36		MAO-12002000	Pin		2
37		RE-0320000-K0	Snap ring		4
38		GAK-01004000	Presser lifting lever connecting rod		1
39		GAK-01001000	Presser lifting shaft		1
40		CS-111101D-SH	Thrust collar asm.		1
41		SS-8660530-TP	Screw 1/4-40 L=4.5		(2)
42		GAK-01002000	Presser lifting lever		1
43		SS-7151210-SP	Screw 15/64-28 L=12.0		1
44		GAK-01003B00	Presser lifter stopper (B)		1
45		GAK-01003A00	Presser lifter stopper (A)		1
46		NM-6060003-SC	Nut M6 x 1		2
47		B3426-552-000	Snap ring		2
48		GAK-010220B0	Knee switch for presser lifter B asm.		1
49		GAK-010220A0	Knee switch for presser lifter A asm.		(1)
50		D9204-555-C00	Microswitch		(1)
51		MAT-80231T00	Switch connecting rod		(1)
52		MAT-80230T00	Switch connecting block		(2)
53		SS-7111410-SP	Screw 11/64-40 L=4.0		(2)
54		SS-6151220-SP	Screw 15/64-28 L=11.5		(4)
55		SK-3514000-SD	Wood screw		2
56		GAK-02023000	Rubber cap		1

EXCLUSIVE PARTS FOR DLU-450-4

DLU-450-4 専用部品

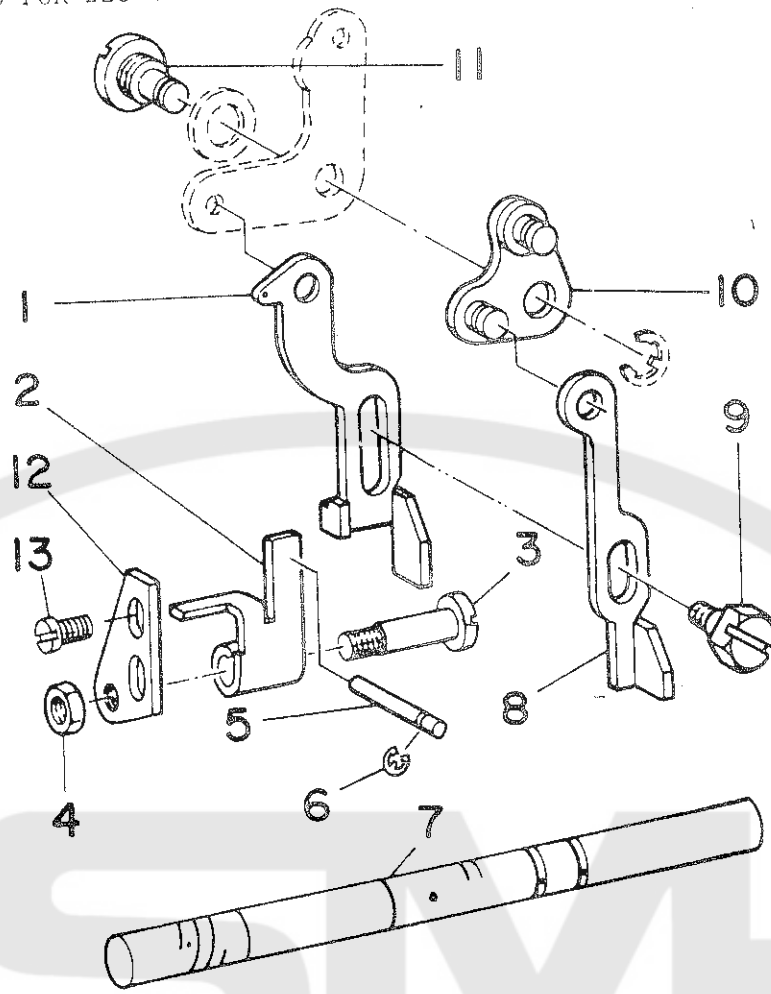

Ref.No.	Note 注記	Part No. 品番	Description	E. C. 変更年月	品名	Amt. Req. 個数
1		D1515-450-B00-A	Lifting lever		引き上げ板	1
2		D3157-450-B00-A	Thread tension release plate		糸コルメ板	1
3		D3158-450-B00-A	... Shaft		糸コルメ板取付軸	1
4		NS6090310-SP	... Nut		糸コルメ板取付軸ナット	1
5		D3127-450-B00	Tension release supporting pin		糸コルメ補助ピン	1
6		RE0250000-K0	... Snap ring		糸コルメ補助ピン止環	1
7		D1201-450-B00	Main shaft		上軸	1
8		D3156-450-B00-A	Tension release link		糸コルメリンク	1
9		SD0630275-SP	Lifting lever hinge pin		引き上げ板取付ネジ	1
10		D3157-415-B00	Lifting lever link asm.		糸コルメリンク組(組)	1
11		D1517-415-B00	Lifting lever hinge pin		引き上げ板リンク軸	1
12		D3159-450-B00	Thread tension release plate mounting base		糸コルメ板取付台	1
13		SS6090510-SP	... Screw		糸コルメ板取付台止ネジ	2
<p>*All parts not mentioned above are same as exclusive parts for automatic undertrimmer and DLU-450. 上記以外の部品は 自動系切り装置専用部品 及び DLU-450と共通です。</p>						

8. EXCLUSIVE PARTS FOR DLD-432-4

DLD-432-4 専用部品

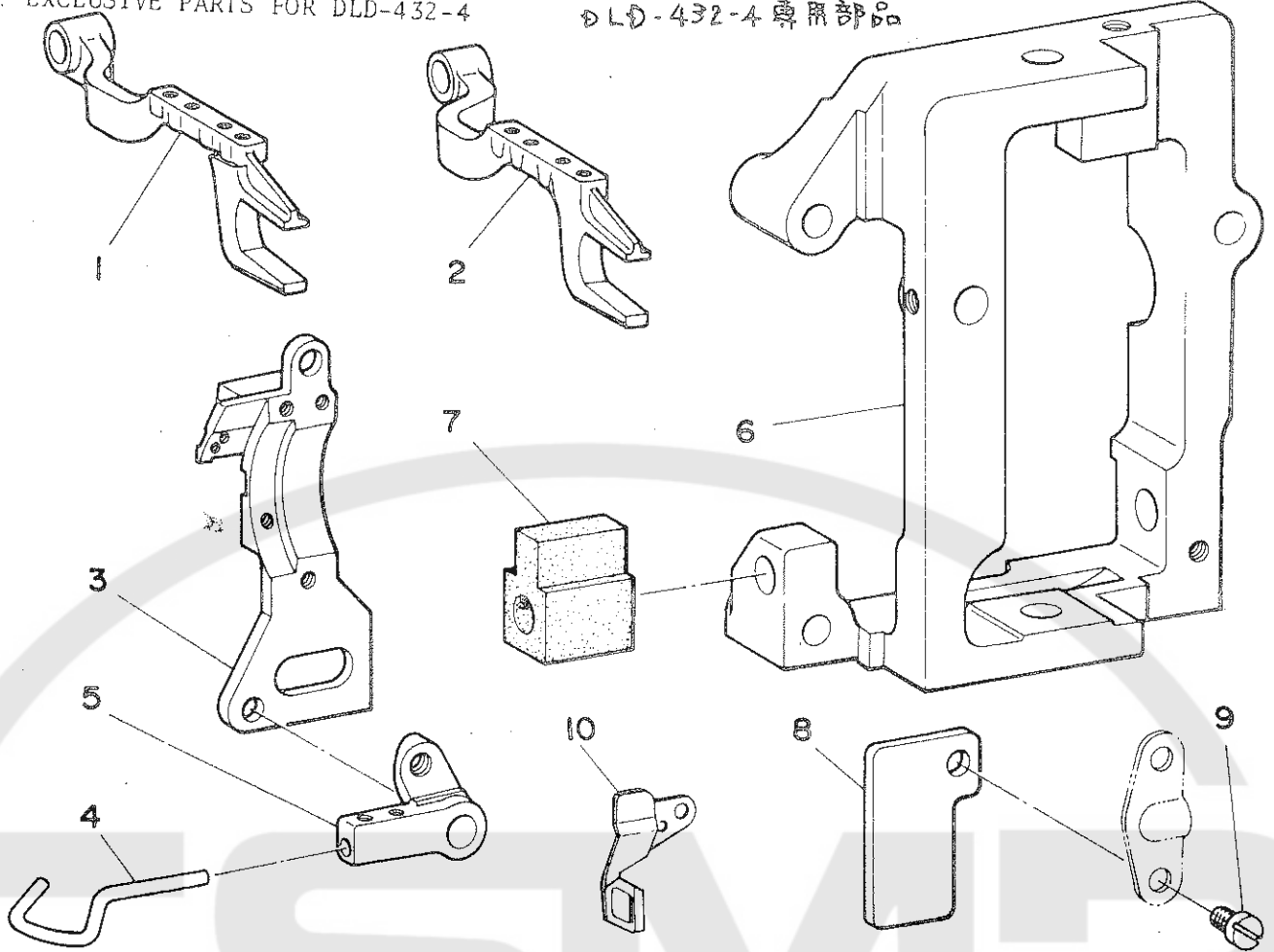

Ref.No.	Note 注記	Part No. 品番	Description	E. C. 変更年月	品名	Amt. Req. 個数
1		D1608-432-B00	Differential feed bar		差動送り台	/
2		D1607-432-B00	Main feed bar		送り台	/
3		D2401-432-B00A	Knife mounting base		メス取付台	/
4		D2408-432-CA0	Take-up thread picker asm.		糸系押エ(組)	/
5		D2420-432-B00	Mounting bracket		糸系押エ腕	/
6		D2412-432-B00	Thread trimmer mounting base		糸切り取付台	5
7		D2426-432-B00	Oil sponge		メス作動軸モルトアブレン	/
8		D2422-432-B00	Groove cover		ゴット蓋フタ	/
9		SS-7110740TP	Screw (B), for oil holder		送り軸油心押エ止ネジ(B)	/
10		D2405-432-B00	Thread guide, for knife		メス糸案内	10
<p>* All parts not mentioned above are same as exclusive parts for automatic undertrimmer and DLD-432.</p> <p>上記以外の部品は 自動糸切り装置専用部品 及び DLD-432 と共通です。</p>						

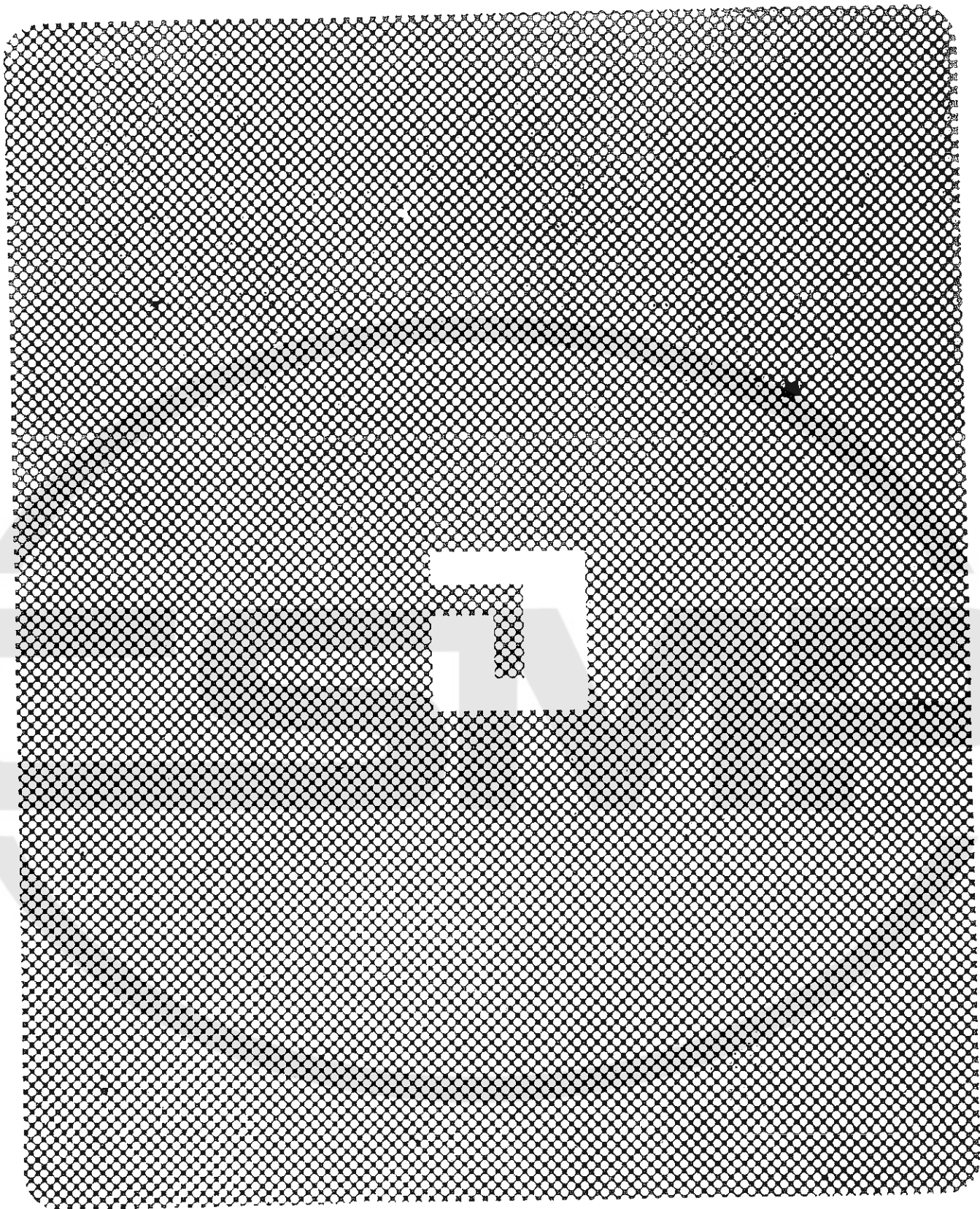

JUKI
TOKYO JUKI INDUSTRIAL CO., LTD.

Address : 23-3, Kabuki-cho 1-chome, Shinjuku-ku,
Tokyo 160, Japan
Cable : JUKI TOKYO
Telex : 22967; 232-2301
Phone : 03 (205) 1188, 1189, 1190

東京重機工業株式会社

〒182
東京都調布市国領町8-2-3 TEL.0480-1111(大代)